



ePANEL 2/3P series Bilge Alarm with Intelli-Mute



Captains and crew want the ability to mute an audible alarm system. However, there is concern that the mute feature will accidentally be left on, rendering the audible alarm in-active. The new e-Panel P series with Intelli-mute is the answer. We've incorporated a single blade style fuse with cover into the face of the panel, making it easy to replace and safer for your equipment and boat. Installation is easy and you may be able to use your existing wires. The ePanel P series allows you to upgrade your current manual on-off-automatic system to an audible / visual bilge alarm with a fuse. By constant monitoring, Intelli-Mute eliminates the possibility of accidentally activating the mute feature and forgetting the alarm has been muted. Once the Mute button is pressed, Intelli-Mute first silences the audible alarm, leaving the back-lit button flashing as a visual reminder. If after 5 minutes, the alarm is still muted, Intelli-Mute turns off the mute feature. The audible alarm is then reactivated warning that an alarm condition is still present and needs to be resolved. Once the alarm condition is resolved, whether the mute feature is enabled or not, Intelli-Mute resets the panel back to the default ready mode.

FEATURES & BENEFITS

- *Built-in easy access blade style fuse*
- *2 or 3 way 20 amp sealed rocker switch*
- *Built with both visual and audible alarms*
- *Temporarily silence alarm with Mute feature*
- *Delayed alarm signals your pump has been running for 2 minutes*
- *Built with Intelli-Mute –mute cannot be left on*
- *Exceeds both United States Coast Guard and U.L. Standards*

SPECIFICATIONS

Power required:	12Vdc (ePANEL 2/3P) 24Vdc (ePANEL 2/3P-24)
Switch:	2 or 3 way 20 amps
Power at rest:	.006 Amps
Power used:	.062 Amps
Size:	4.6"W x 2.4"H x 2.125"D
Weight:	8.75 ounces

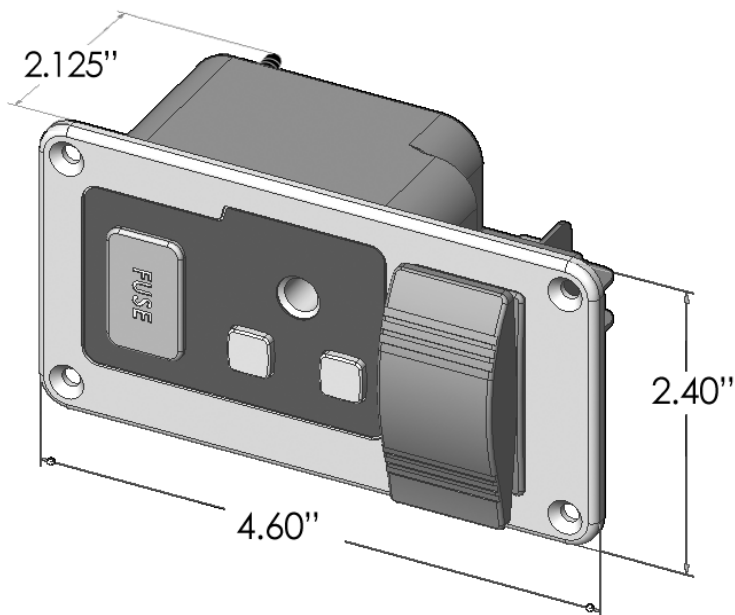

Installation / Wiring Instructions

1. Disconnect the battery.
2. Select a mounting location for the e-Panel which is easy to see from the helm. Check behind mounting panel for clearance (≈3 inches), referring to diagram for dimensions.
3. Cut the opening using the enclosed template as a guide for cutting the hole. De-burr the hole and insert the e-PANEL to check for proper fit. **DO NOT FORCE e-PANEL INTO HOLE.**
4. Follow the e-PANEL wiring schematic as illustrated in the diagram. The fuse is determined by the output load. Check with the manufacturer of the device to determine the correct size.
5. **For All ePanels**—connect the positive (+) post to the positive side of the battery; connect the negative post to ground.
6. **For 2 position switches**—*From the Blower / Pump:* connect the positive wire to the #3 switch terminal; connect the negative wire to ground.
7. **For 3 position switches**—*From Pump:* connect positive wire to #1 switch terminal; connect negative wire to ground. *From the Water Witch:* connect RED wire to the #3 switch terminal; splice TAN wire into the connection from the pump to the #1 terminal on switch; connect the black wire to ground.
8. Check all wires to ensure proper connections and place e-PANEL in hole at the desired position. Tighten the e-PANEL against the mounting surface until flush and secure. **DO NOT over tighten;** it may crack housing or mounting dash.
9. Reconnect the battery. The installation is complete.



ePanel 2P
Black on Black

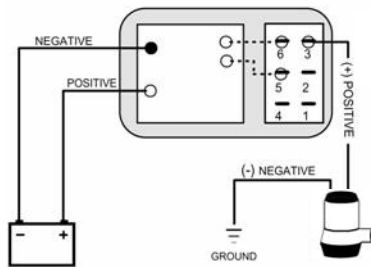

2 position switch diagram

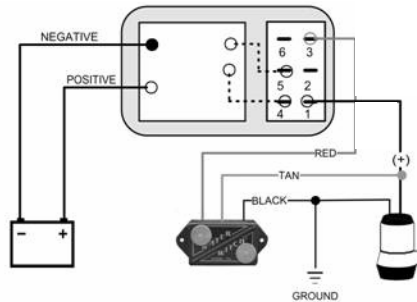

3 position switch diagram



ePanel 3P
Standard

Operating Instructions

- When power is applied, the alarm pulses three times with both buttons flashing indicating the e-Panel and Intelli-mute are active and working.
- If the device connected to the e-Panel runs for 2 minutes on either auto or manual Intelli-mute considers this an alarm condition and sounds the audible alarm.
- Once an alert condition occurs, Intelli-mute activates the pulsing audible alarm and will continue to sound as long as an alarm condition is present.
- Pushing Mute silences the alarm but leaves the button flashing as a visual reminder.
- If after 5 minutes of being muted, the alarm condition still exists, Intelli-mute restarts the alarm cycle; i.e. if the device connected to the e-Panel runs for more than 2 minutes, the audible alarm will sound again. This cycle continues until the alarm condition is resolved.
- Only when the alarm condition is resolved will Intelli-mute automatically reset the e-Panel back to the default ready mode (armed and un-muted).
- The TEST button allows a quick check of the e-Panel's audible output and visual flash mode buttons. Pressing the TEST button during an alarm mode will not affect the alarm condition.
- If the mute button is accidentally pressed and there is no alarm condition, the ePanel resets to its ready mode after 5 minutes.



ePanel 3P
White on White

PURCHASE INFORMATION

Name	Size	Switch	Bezel*	Color	Voltage	Warranty
ePanel 2P	4 $\frac{3}{8}$ " W x 2 $\frac{5}{8}$ " H x 2 $\frac{1}{8}$ " D	2 way	Aluminum*	Black or White	12Vdc or 24Vdc (Epanel-24)	2 years
ePanel 3P	4 $\frac{3}{8}$ " W x 2 $\frac{5}{8}$ " H x 2 $\frac{1}{8}$ " D	3 way				

*Choice of black or white powder-coat

Water Witch, Inc. 10744 Rockvill Street, Suite 103 Santee, California 92071
Phone: 800-654-4783 e-mail: info@waterwitchinc.com www.waterwitchinc.com