



ePANEL 2/3A series Delayed Alarm with Audible Reminder



Never forget your pump or blower is running again with the new e-Panel A series, a clever extension of the PA 300 programmable alarm. We've incorporated a single blade style fuse with cover into the face of the panel, making it easy to check and safer for your equipment and boat. Installation is easy and you may be able to use your existing wires. The ePanel A series allows you to upgrade your current manual on-off-automatic system to a programmable alarm and fuse. At the touch of a button, this electronic audible timer provides preset times from 1 to 15 minutes. The built-in stainless steel piezo buzzer sounds to indicate that time has expired. If mute is pressed, the ePanel silences the alarm and begins counting down the selected time cycle again. The e-Panel A series is the perfect solution for reminding boat owners that a bilge blower or other device is still running thereby, preventing excessive battery drain or possible equipment damage.

FEATURES & BENEFITS

- Preset times from 1 to 15 minutes at the touch of a button
- Never forget your blower / pump is running
- 2 or 3 way 20 amp sealed rocker switch
- Built-in easy access blade style fuse
- Pressing mute restarts the timed cycle again
- 12Vdc or 24Vdc models available
- Exceeds both United States Coast Guard and U.L. Standards

SPECIFICATIONS

Power required: 12Vdc (ePANEL2/3A)
24Vdc (ePANEL2/3A-24)

Rocker switch: 2 or 3 way 20 amps

Power at rest: .020 Amps

Power at alarm: .250 Amps

Size: 4.6"W x 2.4"H x 2.125"D

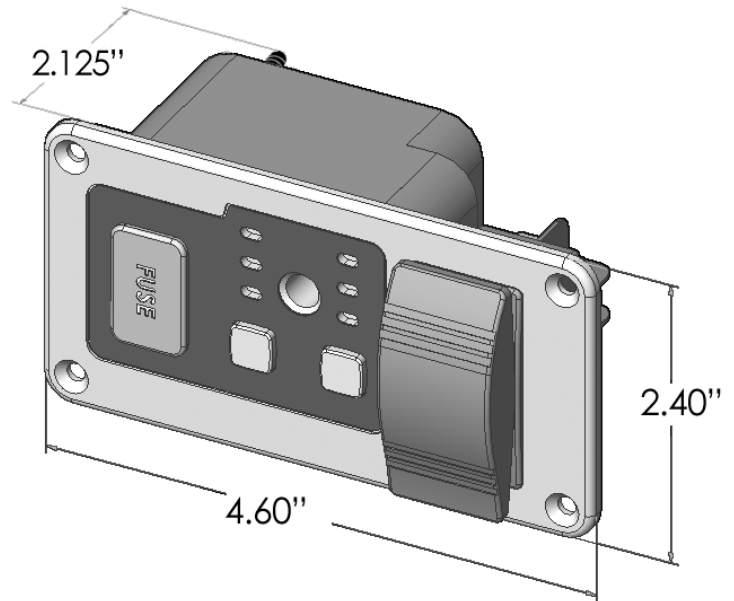

Installation / Wiring Instructions

1. Disconnect the battery.
2. Select a mounting location for the e-PANEL which is easy to see and hear from the helm. Check behind mounting panel for clearance (≈3 inches), referring to diagram for dimensions.
3. Use the enclosed template as a guide for cutting the hole.
4. Cut the opening, following the instructions on the provided template. De-burr the hole and insert the e-PANEL to check for proper fit. **DO NOT FORCE e-PANEL INTO HOLE.**
5. Follow the e-PANEL wiring schematic as illustrated in the diagram. The fuse is determined by the output load. Check with the manufacturer of the device being controlled to determine the fuse size.
4. **For All ePanels**—connect the positive (+) post to the positive side of the battery; connect the negative post to ground.
5. **For 2 position switches**—From the Blower / Pump: connect the positive wire to the #3 switch terminal; connect the negative wire to ground.
6. **For 3 position switches**—From Pump: connect positive wire to #1 switch terminal; connect negative wire to ground. From the Water Witch: connect RED wire to the #3 switch terminal; splice TAN wire into the connection from the pump to the #1 terminal on switch; connect the black wire to ground.
7. Check all wires to ensure proper connections and place e-PANEL in hole at the desired position. Tighten the e-PANEL against the mounting surface until flush and secure. **DO NOT over tighten;** it may crack housing or mounting dash.
8. Reconnect the battery. Installation is complete.



*ePanel 2A
Black on Black*



*ePanel 3A
White on black*



*ePanel 3A
White on White*

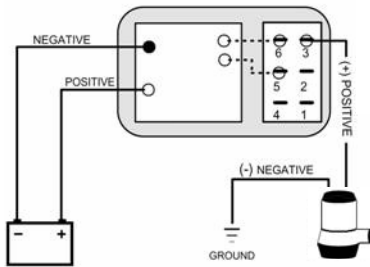

2 position switch diagram

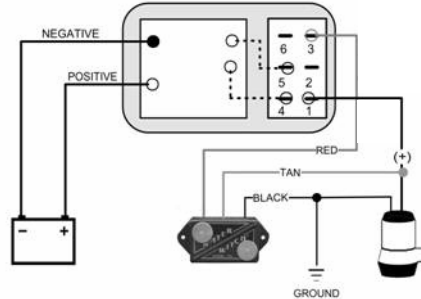

3 position switch diagram

Operating Instructions

- When the monitored device is turned on, it will apply power to the e-PANEL.
- The time setting is stored in memory, repeating whenever the monitored device is activated.
- Pressing the SET DELAY button with power applied changes the timing selection.
- When the device monitored is left on longer than the selected time setting, the audible alarm will sound to remind the vessel operator to shut off the device.
- The MUTE button will silence the audible alarm but the attached device will continue to run.
- The MUTE button resets the internal timer and repeats the selected time interval again before reactivating the audible alarm.

PURCHASE INFORMATION

Name	Size	Switch	Bezel*	Color	Voltage	Warranty
ePanel 2A	4 ³ / ₅ "W x 2 ³ / ₅ " H x 2 ¹ / ₈ "D	2 way	Aluminum*	Black or White	12Vdc or 24Vdc (ePANEL-24)	2 years
ePanel 3A	4 ³ / ₅ "W x 2 ³ / ₅ " H x 2 ¹ / ₈ "D	3 way				

*Choice of black or white powder-coat

Water Witch, Inc.
1-800-654-4783

10744 Rockvill Street, Suite 103
e-mail: info@WaterWitchInc.com

Santee, California 92071
www.WaterWitchInc.com