



MEMBER  
**ABYC**<sup>®</sup>  
Setting Standards for Safer Boating

## Model BA200 The Bilge Monitor



The new BA200 is a hybrid panel, combining all the best features from our controls and technology. Not only is it a bilge pump monitor but also a counter and control. The BA200 keeps a 2 week history of pump cycles and displays a grand total, followed by how many times the pump cycled in the past 24 hours, 7 days and 14 days. With 3 modes, Auto, Alert and Manual, you chose how you want the control to respond.

- **Alert Mode**– In this default mode, the water sensing light illuminates once water is detected for more than 6 seconds there by eliminating false alarms or incorrect bilge counts. If water is detected for more than 2 minutes, the audible alarm will sound, however, the bilge pump WILL NOT start automatically and must be engaged manually.
- **Auto Mode**- When engaged, the Auto button illuminates. When water is detected, the pump instantly starts and the pump count total is displayed. Audible alarm signals after 2 minutes of continuous operation.
- **Manual Mode**- Pressing the pump on button engages the bilge pump. The button lights up indicating that the pump is running and will need to be turned off. There is no audible signal in manual mode. The Mute button will silence the audible alarm in any mode however the mute button will continue flash as a reminder until the condition is resolved.

### FEATURES & BENEFITS

- *Bilge pump counter, control & monitor in 1 panel*
- *Tracks pump cycles for the preceding 14 days*
- *Mute feature allows alarm to be silenced*
- *Both visual and audible alarms*
- *Auxiliary input for high water sensor (such as the Water Witch 23-12)*
- *Exceeds both the United States Coast Guard and U.L. Standards*

### SPECIFICATIONS

Power required: 12Vdc or (24Vdc Available)  
Contact Rating: 20 Amps@12Vdc (15 Amps@24Vdc)  
Power at alert: .020 Amps  
Power at auto: .035 Amps  
Size: 4.56"W x 3.25"H x 2.5"D  
Weight: 12.5 ounces  
Delay: 6 seconds

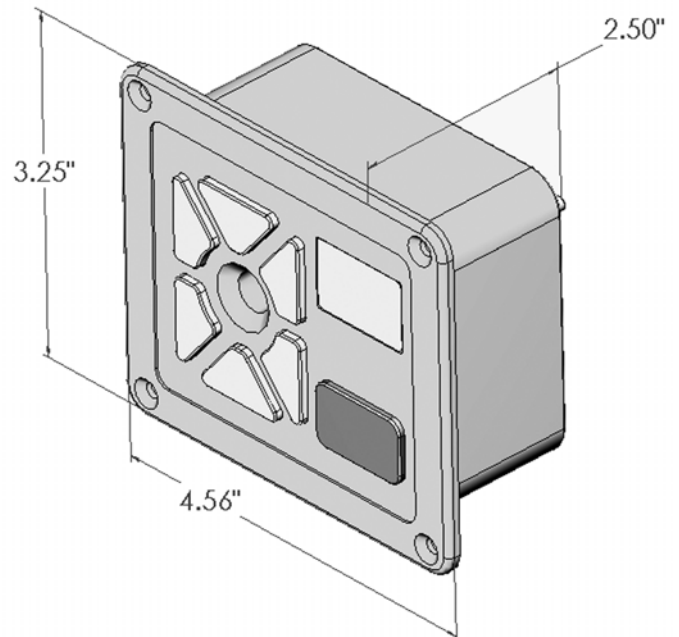

## Installation Instructions

1. Disconnect the battery.
2. Select a mounting location for the monitor which is easy to see from the operating position. Check sufficient clearance.
3. Use the enclosed template as a guide for cutting the hole. CAUTION: a square mounting hole eliminates too much material in the corners to support mounting screws properly.
4. Cut the opening, following the instructions on the provided template. De-burr the mounting hole and insert the BA200 to check for proper fit. DO NOT FORCE BA200 INTO HOLE.
5. Wire the BA200 as illustrated in the diagram.
6. Check with the bilge pump manufacturer to determine the correct fuse size.
7. Mount the BA200 using the enclosed #6 screws. Be careful not to over tighten the terminal nuts or mounting screws as they may crack the monitor housing or mounting dash /bulkhead.
8. Check all wires to ensure proper connections then reconnect the battery. When power is applied correctly, the center segment of the display scrolls horizontally, indicating the monitor is ready for operation.
9. **Note: The BA200 has an additional connection posts for a high water sensor (12/24Vdc) such as the model 23-12 and auxiliary output for remote audible device rated up to 5 amps. maximum.**

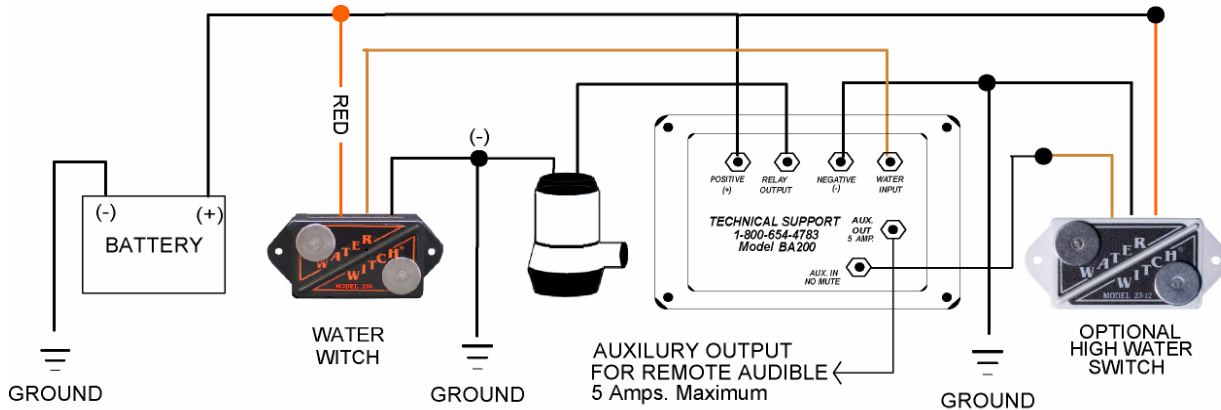

### PUMP ON

Manual mode engages when pressed, turning on the bilge pump and illuminating the button. The button must be manually turned off. There is no audible signal in manual mode. Press and hold this button for a function test. During a function test, the BA200 will step through all modes, returning to alert mode.

### AUTO

Auto mode engages when pressed and the button illuminates. When in auto mode, the detection of water will immediately engage the bilge pump and display the total cycle count. After 2 continuous minutes of operation an audible alarm sounds. While pump is running the PUMP ON light remains illuminated.

### Mute

Once pressed, the audible alarm is silenced, leaving only the button flashing as a reminder. The monitor remains muted until this button is pressed again, thereby cancelling the mute feature. Holding the mute button down will reset the counter.

### DISP

The display will scroll total number of times that the pump has cycled in the past 24 hours, 7 days and 14 days. When the cycle counts for any time period are flashing, this means that power has been interrupted and these counts may be invalid. Only after having continuous power for that time period will a count not be flashing. Total count will not be lost with power loss.

### OFF/ALERT

When powered, the BA200 monitor starts and remains in alert mode until another is selected. The WATER SENSE light illuminates when water is detected for more than 6 seconds and if detected for more than 2 minutes, an alarm sounds. The bilge pump will NOT automatically start in this default mode and must be engaged manually. The BA200 always counts manual bilge pump cycles and maintains a 14 day cycle history.



### LED Display

Illuminates when the pump runs showing total cycle count since the BA200 was last reset.

### Fuse Cover

The bilge pump's amperage will determine the size of the fuse necessary. Use an appropriately rated fuse as recommended by the manufacturer of the device being controlled.

### Water Sense

The WATER SENSE Light illuminates after water is sensed for more than 6 seconds.

## PURCHASE INFORMATION

Name	Model #	Bezel	Color*	Voltage	Limited Warranty
Bilge Monitor	BA200-12	Aluminum	Black or White	12Vdc	2 years
Bilge Monitor	BA200-24	Aluminum	Black or White	24 Vdc	2 years